

# EXS210035-01

EXS0650-010-05-0M00030

650nm UNCOOLED TO-56 MPD

**Revision:** 1.0  
**Date:** 15-12-2011  
**Confidentiality:** **None**

**Prepared by:** Raffaele Rezzonico  
(Product Support Technician)

**Checked by:** Chris Armistead  
(Engineering Manager)

**Approved by:** Philippe Crépeillère  
(Quality Manager)

**Authorized by:** Marcus Duelk  
(CTO)

## **CONTENTS**

<b>1. SCOPE.....</b>	<b>3</b>
1.1 PURPOSE.....	3
1.2 RESPONSIBILITY .....	3
<b>2. REFERENCE DOCUMENT.....</b>	<b>3</b>
<b>3. ELECTRO-OPTICAL PERFORMANCE (T<sub>SLED</sub> = 25°C) .....</b>	<b>3</b>
<b>4. ABSOLUTE MAXIMUM RATINGS .....</b>	<b>4</b>
<b>5. SCREENING (EXS210035-01) .....</b>	<b>4</b>
<b>6. PACKAGE DIMENSIONS [mm].....</b>	<b>5</b>
6.1 DETAILED DIMENSIONS [mm] .....	6
<b>7. IMPORTANT NOTES.....</b>	<b>7</b>
<b>8. ORDERING INFORMATION.....</b>	<b>7</b>
9.1 TECHNICAL DESCRIPTION.....	7
<b>9. REVISION HISTORY .....</b>	<b>8</b>

## 1. SCOPE

### 1.1 PURPOSE

The purpose of this document is to specify the electro-optical performance and dimensions of superluminescent light emitting diode (SLED) TO-56.

### 1.2 RESPONSIBILITY

EXALOS is responsible for establishing, implementing and maintaining this procedure. The Quality representative shall ensure that a timely Engineering Change Notice (ECN) is issued in accordance with EXALOS procedure for any changes.

## 2. REFERENCE DOCUMENT

- EXS-WI-0001 Visual Inspection Criteria SLED Chip on Submount Procedure
- MIL STD 883 C method.
- Bellcore GR-468-CORE

## 3. ELECTRO-OPTICAL PERFORMANCE ( $T_{SLED} = 25^{\circ}C$ )

Parameter	Symbol	Min	Typ	Max	Unit
Operating Current	$I_{op}$	0		100	mA
Power ex-window	$P_o$	1	3	-	mW
Centre Wavelength*	$\lambda_c$	630	650	670	nm
Bandwidth FWHM*		8	10	-	nm
Spectral ripple [RB=0.1 nm]		-	0.1	-	dB
Vertical Far Field Angle FWHM		-	40	-	degrees
Horizontal Far Field Angle FWHM		-	15	-	degrees
PD Monitor Current <sup>†</sup>	$I_m$	0.1		5	mA
PD Monitor Bias Voltage	$V_b$	0		-12	V

\*Spectral verification is performed by sampling at the manufacturing batch level. Manufacturing batches are defined by epitaxial wafer growth run

<sup>†</sup> Measurement conditions:

$I_{op} = I_{op} \text{ Max}$

Monitor PD bias voltage: 0 Volts

Input resistance of the Monitor PD current measurement circuit 10 Ohm

#### 4. ABSOLUTE MAXIMUM RATINGS

Stresses beyond the absolute maximum ratings may cause permanent damage to the device.  
Exposure to absolute maximum rating conditions for extended periods may affect device reliability.

Parameter	Symbol	Cond.	Min	Max	Unit
Forward current	$I_F$			120	mA
Reverse voltage	$V_R$			-2	V
Forward voltage	$V_F$	$I_{F,max}$		2.5	V
Storage temperature	$T_{stg}$		-40	85	°C
Operating temperature	$T_{op}$	$I_{F,max}$	-20	65	°C
Lead soldering temperature				260	°C
ESD		human b.m		500	V

#### 5. SCREENING (EXS210035-01)

The produced 650nm SLED Module is required to meet all operating conditions specified in Table 4.1, Electro-Optical Performance Specifications after being subjected to the following screening tests.

Test Item	Test Conditions	Reference	Sample
Hermetic Seal	Fine leak :	MIL-STD-883, Method 1014	100 %
	Max. leak rate $5 \times 10^{-8}$ atm.cc/sec	Condition A	
Temperature Cycling	Gross leak :	MIL-STD-883, Method 1014	100 %
	-40°C to +85°C, ramp rate $\geq 5^\circ$ C/min 20 cycles	Condition C	
		MIL-STD-883, Method 1010	100%

**6. PACKAGE DIMENSIONS [mm]**

Tolerances: See section 6.1

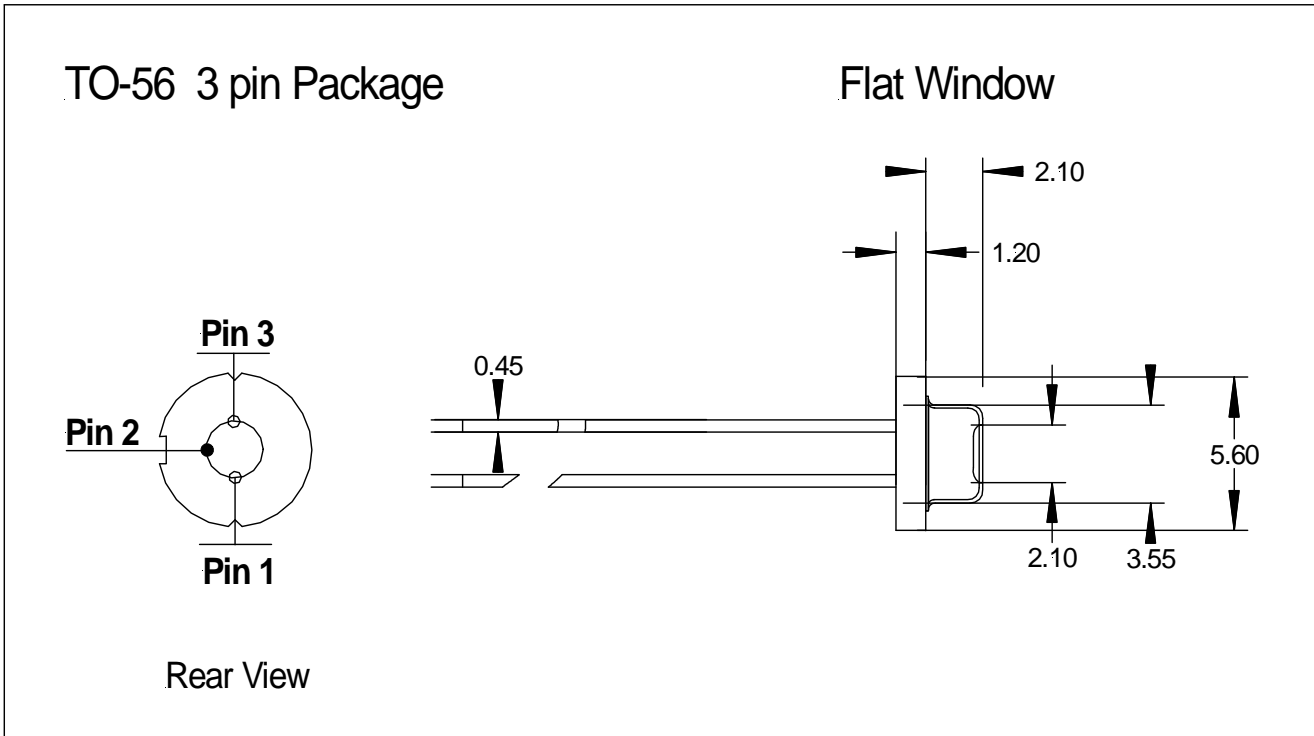

EXS210035-01	
Pin	Function
1	SLED CATHODE (-)
2	SLED ANODE (+), MONITOR DIODE CATHODE, CASE
3	MONITOR DIODE ANODE

**SCHEMATIC PIN LAYOUT**

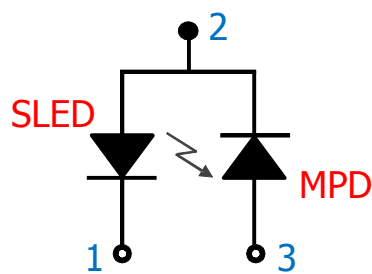

**6.1 DETAILED DIMENSIONS [mm]**

**Side View Cross-section**

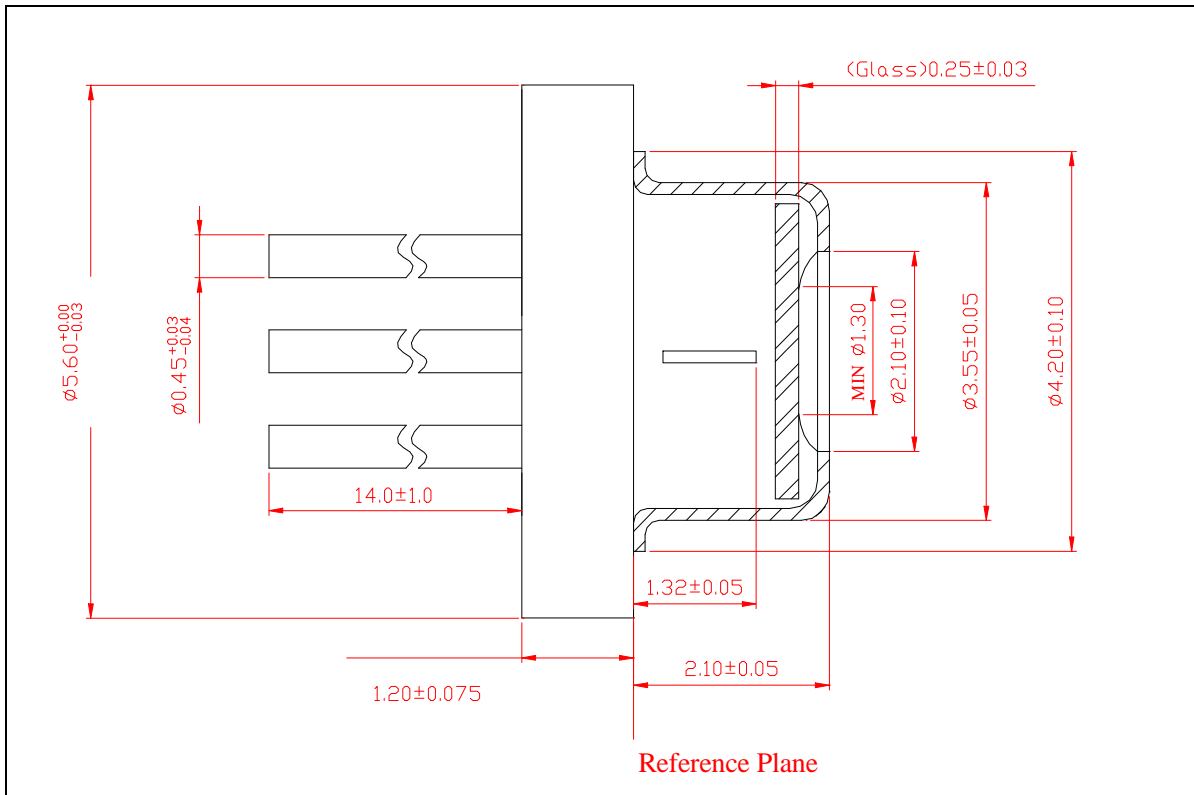

**Top View**

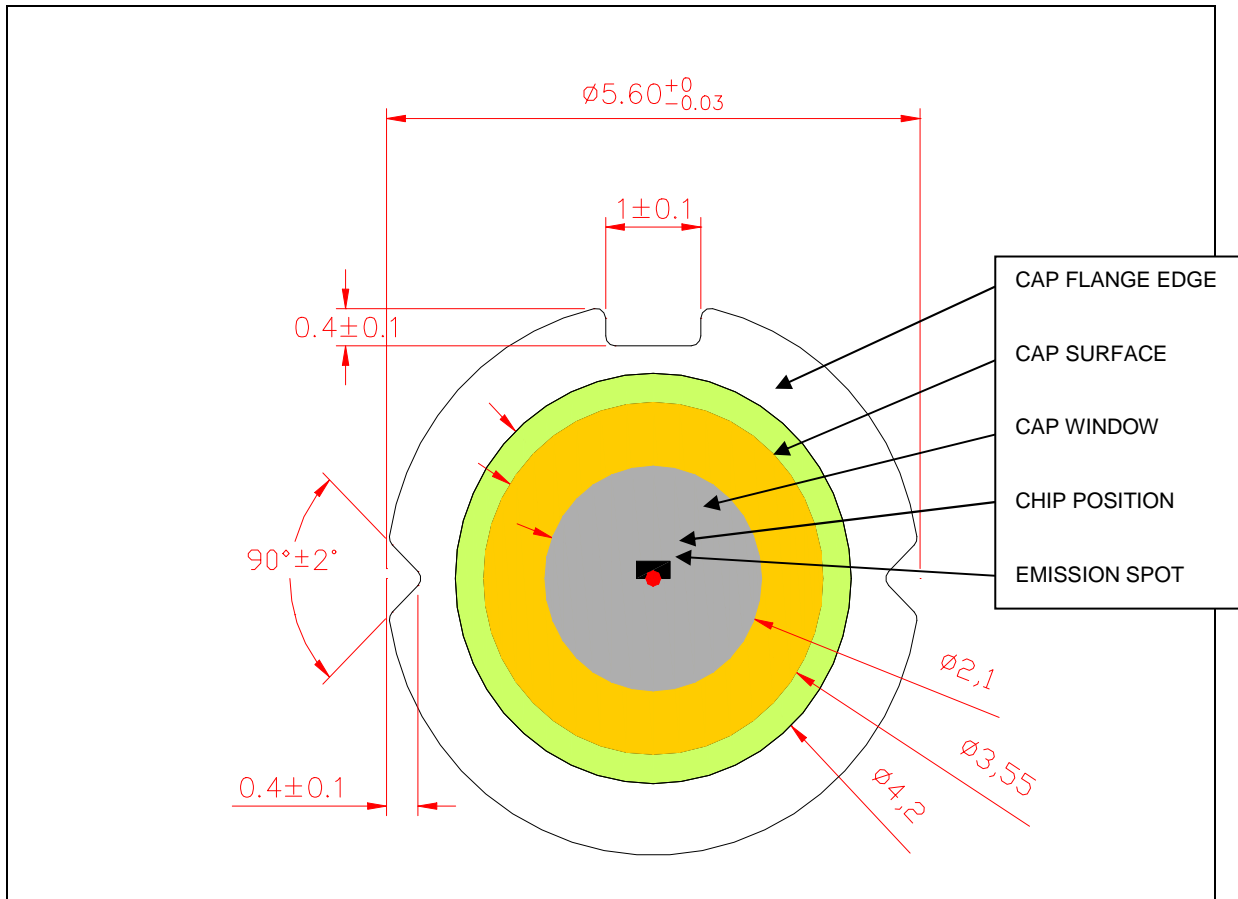

## 7. IMPORTANT NOTES

1. Avoid electrostatic discharges, which may destroy the SLED.
2. Never use the TO-CAN die without heat sinking.
3. Adequate eye protection against laser radiation should be used while handling and operating the module.
4. EXALOS declines any responsibility if the device is used in applications where human life may be endangered.
5. Back reflections may influence the output power and spectral characteristics of the SLED. The use of optical isolators and/or angled connectors is recommended. Back reflections of less than -30dB are recommended.

## 8. ORDERING INFORMATION

Please use the following **part number** to order product from EXALOS:

**E X S 2 1 0 0 3 5 - 0 1**

### 9.1 TECHNICAL DESCRIPTION

